



ever-fast.com

EF-SPL

The lobes around thread diameter of EF-SPL screws allow the thread to be formed easily and also ensuring optimum contact between thread and material..Special designed threads achieve low thread forming torque.

- Special design provides low thread forming torque
- Higher strength properties
- Highly variable installation angles
- Suitable for a wide range of products
- High process reliability

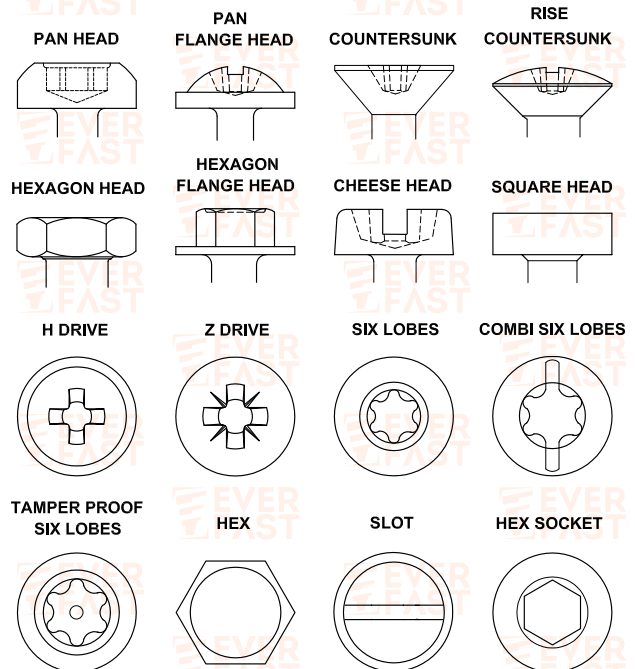
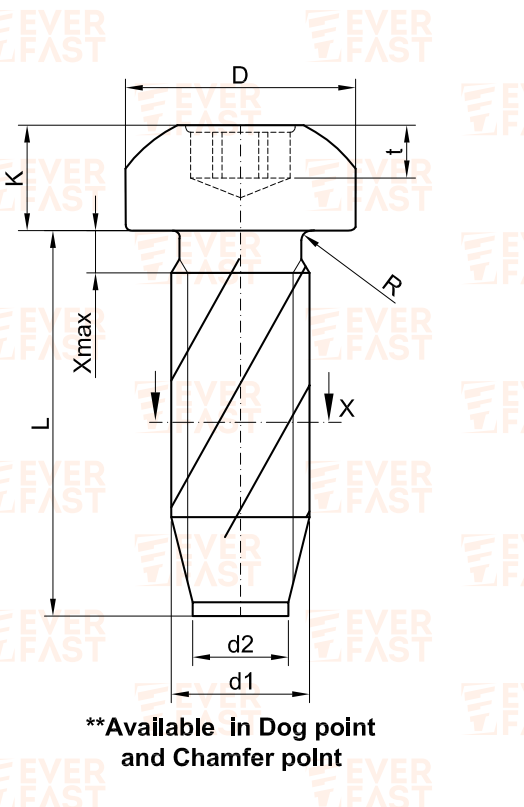

All the EverFast treatments are carried out in full respect of the environment, in compliance with the RoHS and Reach standards, and are free of chromium (VI).

Surface treatments: white, yellow, black, iridescent high-strength zinc plating, zinc-nickel plating, zinc-iron plating, nickel plating, copper plating, tin plating, geomet coating, sealing, lubrication, dehydrogenation, self-locking, stainless steel polishing, blacking - burnishing.

Other treatments on request.